



Acoustical Surfaces, Inc.

Soundproofing, Acoustics, Noise & Vibration Control Specialists

123 Columbia Court North • Suite 201 • Chaska, MN 55318
(952) 448-5300 • Fax (952) 448-2613 • (800) 448-0121

Email: sales@acousticalsurfaces.com

Visit our Website: www.acousticalsurfaces.com

We Identify and **S.T.O.P.** Your Noise Problems



ACOUSTI-LEAD™

Sound Barrier

- ✓ **Effective Noise Plenum Barrier**
- ✓ **Pliable-Ease of Handling**
- ✓ **Easy to Install**
- ✓ **Machinery Noise Barriers**

Acousti-Lead™ is extremely easy to install and can be cut to shape with scissors or knife. Acousti-Lead™ can be molded, folded, creased or crimped to provide a sound-tight seal around any shape, or to fit any enclosure system.

MATERIAL: Lead.

APPLICATIONS: Ceiling plenum barriers – machinery enclosures.

SIZE: Rolls – 4'0" x 25'0".

THICKNESS: 1/64".

WEIGHT: 1 lb.

FLAMMABILITY: Nonflammable.

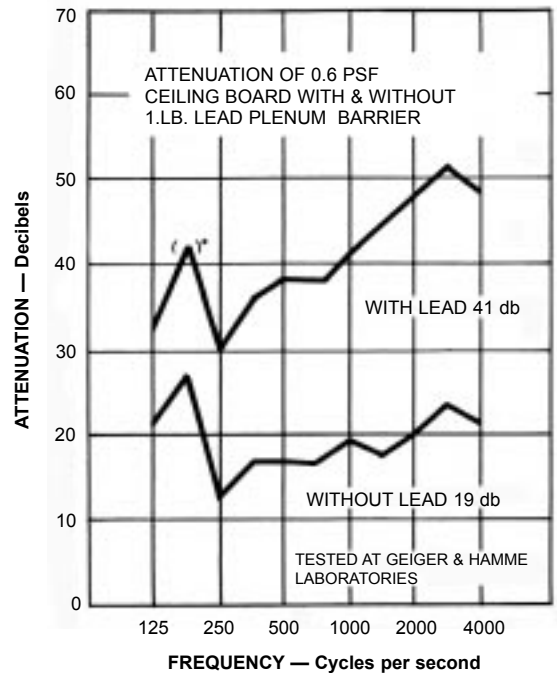
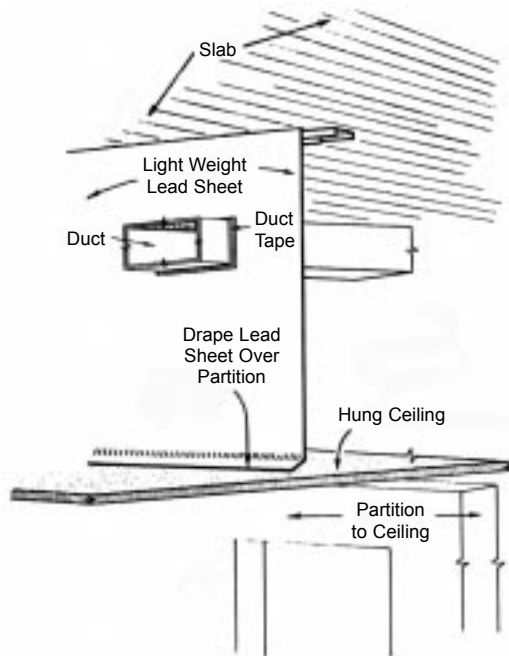



Acoustical Surfaces, Inc.

Soundproofing, Acoustics, Noise & Vibration Control Specialists

123 Columbia Court North • Suite 201 • Chaska, MN 55318
(952) 448-5300 • Fax (952) 448-2613 • (800) 448-0121

Email: sales@acousticalsurfaces.com
Visit our Website: www.acousticalsurfaces.com

We Identify and **S.T.O.P.** Your Noise Problems

Installation Procedures

METHOD #1 (FIGURE 1)

For long runs, plenum depth of 3'7" or less, where run of sheet can be horizontal, notch both top corners of Acousti-Lead™ sheet 3" x 1-1/2", then fold over the 1-1/2" tab for vertical seams, and wrap top edge of sheet around outside of black iron channel. (Figure 2). Fasten channel and lead to underside of deck 24" o.c. providing a minimum 2-1/2" drape at bottom. Provide additional drape and/or auxiliary sealing with tape or staples in accordance with Figure 4.

For plenum depths greater than 3'7", cut length of sheet equal to plenum depth plus 5" and proceed as above using 4' wide sections hung vertically.

METHOD #2 (FIGURE 1)

Alternate for plenum depth 3'3" or less, where run of sheet can be horizontal, notch both top corners of Acousti-Lead™ sheet 7" x 1-1/2" and wrap 1-1/2 times around a spruce or plyscore 1 x 2 not exceeding 8' in length. Fasten ground and lead to deck as in Method #1, providing adequate drape at bottom.

For plenum depths greater than 3'3", cut length of sheet equal to plenum depth plus 7" and proceed as above using 4' wide sections hung vertically.

METHOD #3 (FIGURE 1)

For any plenum depth, under metal deck where no concrete slab is involved. Attach wood blocking to underside of metal deck with sheet metal screws. Notch Acousti-Lead™ 1-1/2 x 2" both corners. Fold Acousti-Lead™ over 1" x 45" batten strip of sheet metal, cardboard, or lath. Staple or nail through lead and batten to blocking.

GENERAL-ALL METHODS

Seams shall be formed by turning up 1-1/2" tab at each vertical edge and sealing with 3" pressure sensitive tape (Figure 3). Pinch stapling 12" o.c. or crimping is optional.

When used as a barrier in controlled air systems, plenum barrier shall have a minimum 4" drape at bottom. Bottom edge shall be taped or sealed with butyl rubber or similar sealant to ceiling or top of partition. Stapling of vertical seams is mandatory for air distributing ceiling systems.

If partition does not penetrate the acoustical ceiling, this joint must be gasketed or caulked and the barrier sheet should overlay the ceiling tiles where they straddle the partition. If metal pan ceiling tiles permit lateral travel of sound through the tiles, steps must be taken to block such leaks. Install Acousti-Lead™ strips in the metal pan under the insulation in all tiles which bridge the partition top or request further specific details.

Any sound barrier must be essentially air tight to give optimum results. This can be readily accomplished with Acousti-Lead™ sheet. There is no better barrier.

FIGURE 1

METHOD #1
1-1/2" Lather's Channel
(1-1/2" x 1/2" 16 ga.)



Shoot Steel Pins into Slab 24" O.C.

METHOD #2
1 x 2 Spruce or Plywood Ground.



Shoot Steel Pins into Slab 12" O.C.

METHOD #3
2 x 2 Block and Batten.



Sheet Metal Screws Into Steel Deck Where Concrete has Not Been Poured.

Metal or Paperboard Batten-Staple or Nail Lead Through Batten 6" O.C.

PREFERRED METHOD

METHODS #1 & 2 can be used under bare metal deck with sheet metal screws.

ALTERNATE METHOD

ALTERNATE METHOD

METHODS #3 requires heavy duty 1/2" staples or broad head nails for fastening lead/batten to block.

FIGURE 2

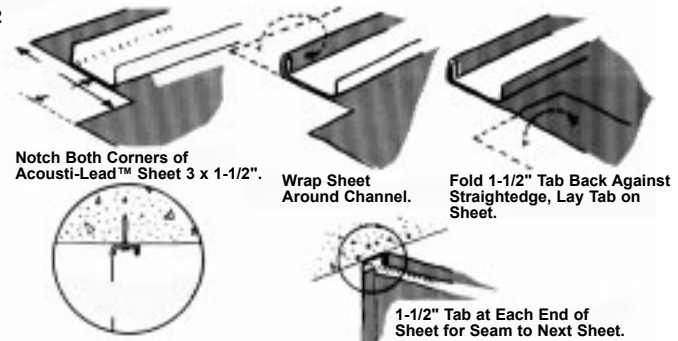

FIGURE 3 Foaming Seams

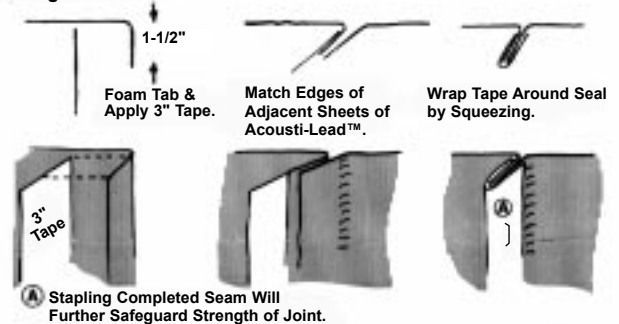
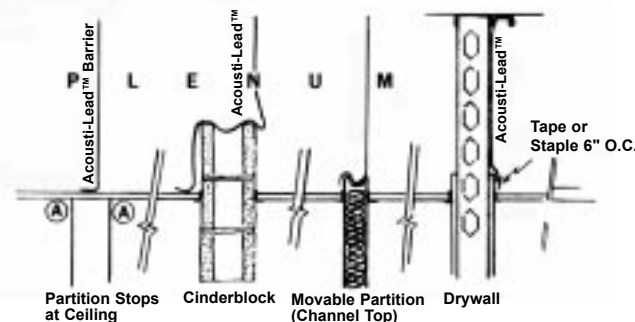

FIGURE 4 Drap Details



NOTE A:
A Joint between ceiling and partition must be sealed.



Acoustical Surfaces, Inc.

Soundproofing, Acoustics, Noise & Vibration Control Specialists

123 Columbia Court North • Suite 201 • Chaska, MN 55318
(952) 448-5300 • Fax (952) 448-2613 • (800) 448-0121

Email: sales@acousticalsurfaces.com

Visit our Website: www.acousticalsurfaces.com

We Identify and **S.T.O.P.** Your Noise Problems

PLENUM BARRIER DETAILS

Fitting Around Pipes, Wires, etc. (Fig-5)

Slit barrier from bottom of sheet to point of penetration as shown and make orange peel slits to accommodate the pipe diameter. Drape Acousti-Lead™ over obstruction and collar tabs tightly against it. Tape securely in place. Draw together the vertical slit edges and tape.

FIGURE 5

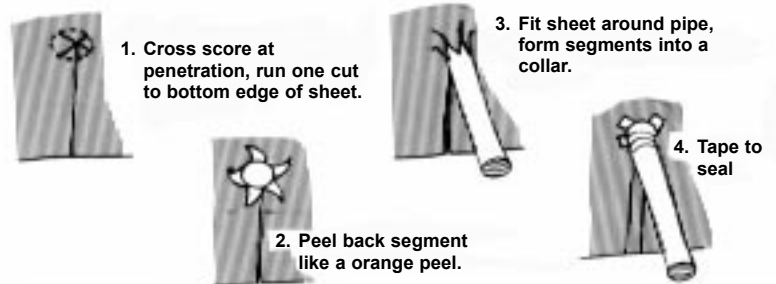

For Small Rectangular Ducts (Fig.6)

Fasten adjoining barrier sheets as illustrated except for forming the standing seam at the vertical edges. Slit barrier sheets diagonally as shown. Turn up the flaps to accommodate duct and tape in place on duct surfaces. Fold and tape vertical edges (Fig. 3) above and/or below duct into tight standing seam. A few feet of barrier sheet lead on top of duct on both sides of partition will reduce drumming noise. Large rectangular ducts should be bridged.

FIGURE 6

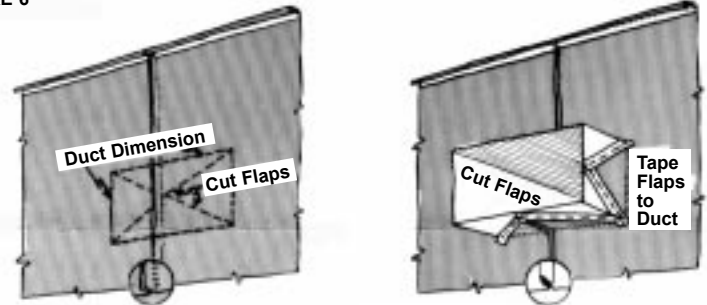

Under "Pan" Type Floors (Fig.7)

Under "pan" type floors, fasten lead sheet to blocking in the usual way. Then cut pieces of 1 lb. Acousti-Lead™ to fit dimensions of cavities in floor construction, allowing for batten or adhesive attachment. Tape bottom edge to blocking or ground. For corrugated steel floors, preformed rubber strips, available from the steel manufacturer, will conform to the flutes in the steel and assure a tight fit. (Figure 8).

FIGURE 7



FIGURE 8

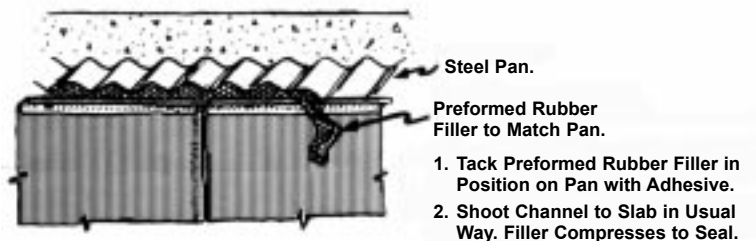

Acousti-Lead™ is also effective as a duct wrap and as a component in doors, walls, partition panels, and remedial supplemental wall panels. When sheet lead is elastomerically laminated to thin panel materials of approximate equivalent weight per square foot, the coincidence dip inherent in the barrier performance curve of all common panel materials is eliminated. Performance of the composite panel is far superior to that of an unleaded panel of equal weight. Additional application information is available upon request.