



Acoustical Surfaces, Inc.

SOUNDPROOFING, ACOUSTICS, NOISE & VIBRATION CONTROL SPECIALISTS

123 Columbia Court North • Suite 201 • Chaska, MN 55318

(952) 448-5300 • Fax (952) 448-2613 • (800) 448-0121

Email: sales@acousticalsurfaces.com

Visit our Website: www.acousticalsurfaces.com

We Identify and S.T.O.P. Your Noise Problem

Acoustical Surfaces, Inc.
A Master Distributor for
PAC INTERNATIONAL, INC.



RSIC-DC04

Dropped Resilient Ceiling

The Sound of Silence

RSIC-DC04 Resilient Sound Isolation DeCouple Clip

The RSIC-DC04™ and RSIC-DC04X2™ are very versatile products. The most common use is the decoupling of wall systems. The design of the RSIC-DC04™ can be used in new construction or retrofit. The RSIC-DC04X2™ is twice as strong as the RSIC-DC04™ for use when heavy items need to be acoustically decoupled for noise isolation. Below are some examples of the possible uses for the RSIC-DC04™.



Continued on next page.

Page 1



Acoustical Surfaces, Inc.

SOUNDPROOFING, ACOUSTICS, NOISE & VIBRATION CONTROL SPECIALISTS

123 Columbia Court North • Suite 201 • Chaska, MN 55318

(952) 448-5300 • Fax (952) 448-2613 • (800) 448-0121

Email: sales@acousticalsurfaces.com

Visit our Website: www.acousticalsurfaces.com

We Identify and S.T.O.P. Your Noise Problem

Dropped Ceiling:

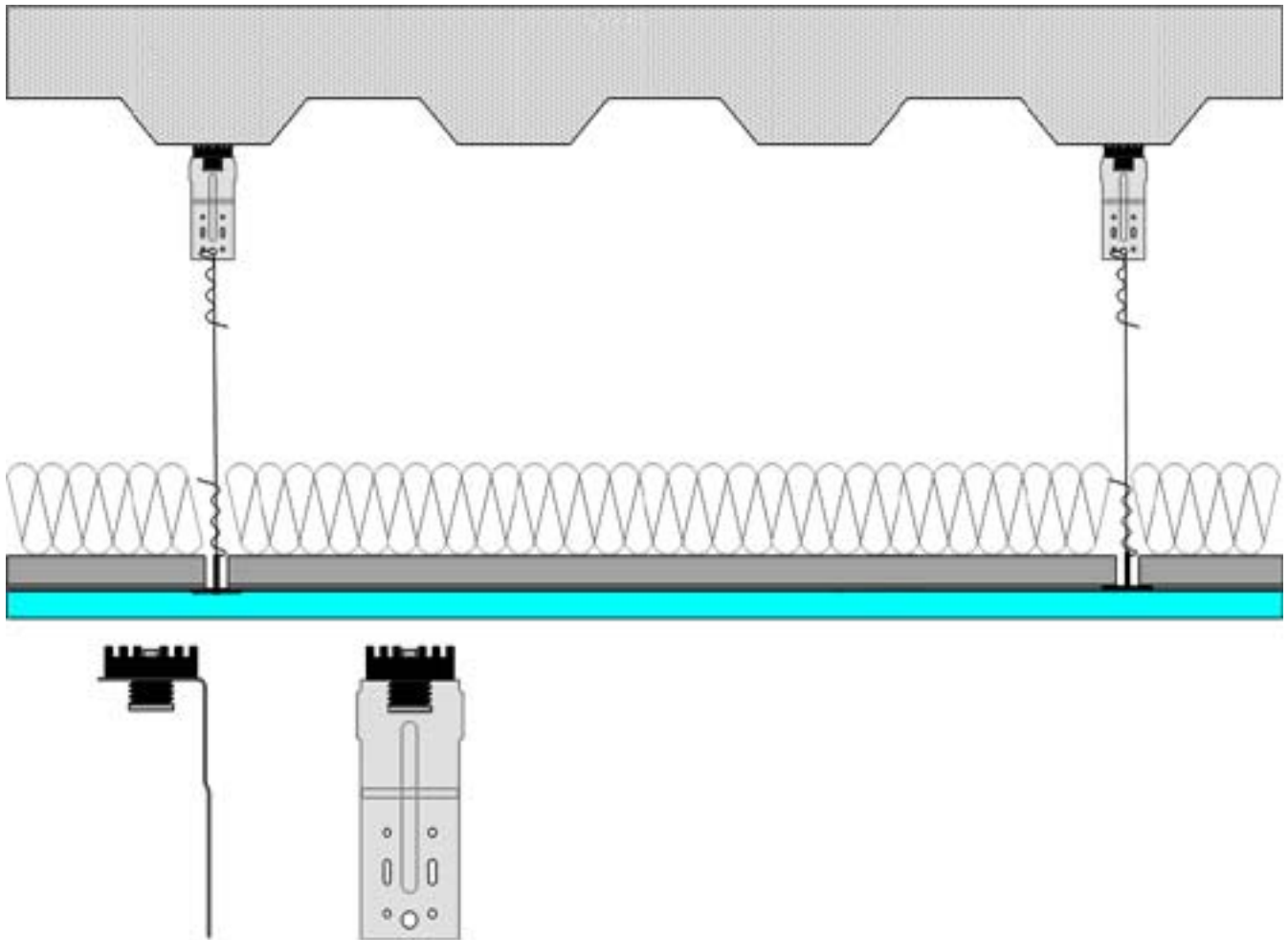

Continued on next page.

Page 2

- Soundproofing Products • Sonex™ Ceiling & Wall Panels • Sound Control Curtains • Equipment Enclosures • Acoustical Baffles & Banners • Solid Wood & Veneer Acoustical Ceiling & Wall Systems
- Professional Audio Acoustics • Vibration & Damping Control • Fire Retardant Acoustics • Hearing Protection • Moisture & Impact Resistant Products • Floor Impact Noise Reduction
- Sound Absorbers • Noise Barriers • Fabric Wrapped Wall Panels • Acoustical Foam (Egg Crate) • Acoustical Sealants & Adhesives • Outdoor Noise Control • Assistive Listening Devices
- OSHA, FDA, ADA Compliance • On-Site Acoustical Analysis • Acoustical Design & Consulting • Large Inventory • Fast Shipment • No Project too Large or Small • Major Credit Cards Accepted



Acoustical Surfaces, Inc.

SOUNDPROOFING, ACOUSTICS, NOISE & VIBRATION CONTROL SPECIALISTS

123 Columbia Court North • Suite 201 • Chaska, MN 55318

(952) 448-5300 • Fax (952) 448-2613 • (800) 448-0121

Email: sales@acousticalsurfaces.com

Visit our Website: www.acousticalsurfaces.com

We Identify and S.T.O.P. Your Noise Problem

Dropped Ceiling Slab:

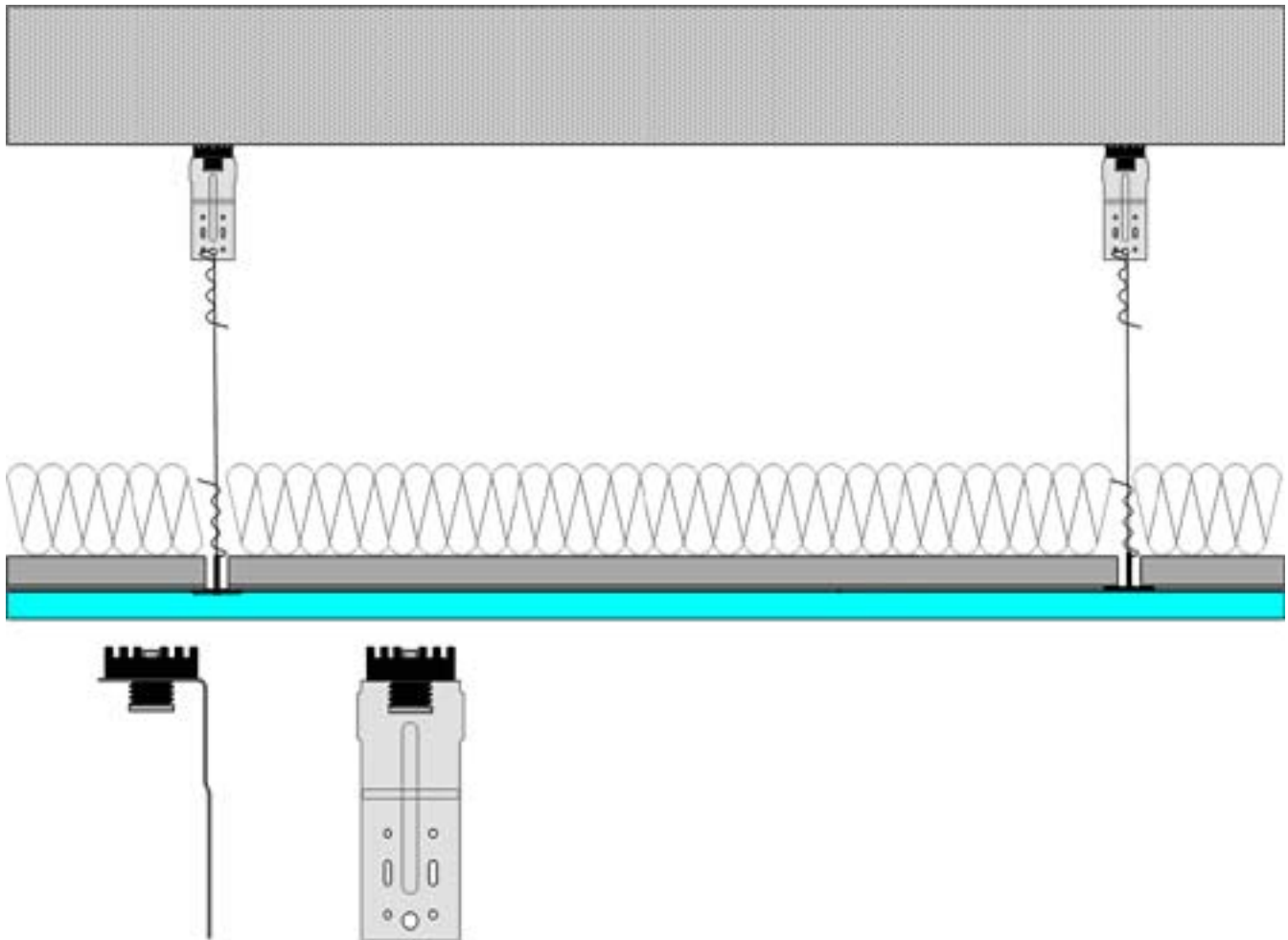

Continued on next page.

Page 3

-
- Soundproofing Products • Sonex™ Ceiling & Wall Panels • Sound Control Curtains • Equipment Enclosures • Acoustical Baffles & Banners • Solid Wood & Veneer Acoustical Ceiling & Wall Systems
 - Professional Audio Acoustics • Vibration & Damping Control • Fire Retardant Acoustics • Hearing Protection • Moisture & Impact Resistant Products • Floor Impact Noise Reduction
 - Sound Absorbers • Noise Barriers • Fabric Wrapped Wall Panels • Acoustical Foam (Egg Crate) • Acoustical Sealants & Adhesives • Outdoor Noise Control • Assistive Listening Devices
 - OSHA, FDA, ADA Compliance • On-Site Acoustical Analysis • Acoustical Design & Consulting • Large Inventory • Fast Shipment • No Project too Large or Small • Major Credit Cards Accepted



Acoustical Surfaces, Inc.

SOUNDPROOFING, ACOUSTICS, NOISE & VIBRATION CONTROL SPECIALISTS

123 Columbia Court North • Suite 201 • Chaska, MN 55318

(952) 448-5300 • Fax (952) 448-2613 • (800) 448-0121

Email: sales@acousticalsurfaces.com

Visit our Website: www.acousticalsurfaces.com

We Identify and S.T.O.P. Your Noise Problem

144 lb. Ceiling Fan - Electrical Box Isolation :

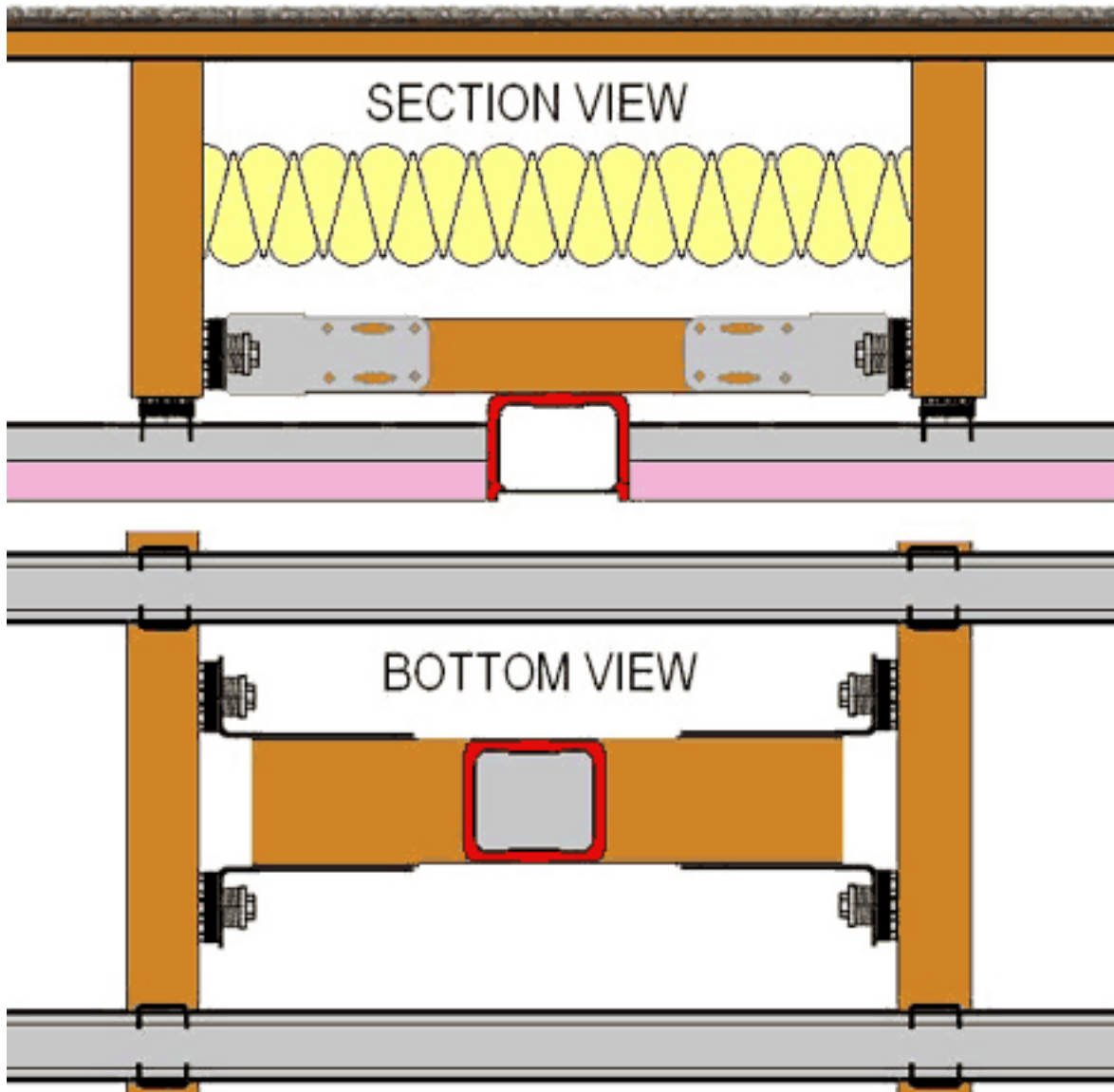

Continued on next page.

Page 4

- Soundproofing Products • Sonex™ Ceiling & Wall Panels • Sound Control Curtains • Equipment Enclosures • Acoustical Baffles & Banners • Solid Wood & Veneer Acoustical Ceiling & Wall Systems
- Professional Audio Acoustics • Vibration & Damping Control • Fire Retardant Acoustics • Hearing Protection • Moisture & Impact Resistant Products • Floor Impact Noise Reduction
- Sound Absorbers • Noise Barriers • Fabric Wrapped Wall Panels • Acoustical Foam (Egg Crate) • Acoustical Sealants & Adhesives • Outdoor Noise Control • Assistive Listening Devices
- OSHA, FDA, ADA Compliance • On-Site Acoustical Analysis • Acoustical Design & Consulting • Large Inventory • Fast Shipment • No Project too Large or Small • Major Credit Cards Accepted



Acoustical Surfaces, Inc.

SOUNDPROOFING, ACOUSTICS, NOISE & VIBRATION CONTROL SPECIALISTS

123 Columbia Court North • Suite 201 • Chaska, MN 55318

(952) 448-5300 • Fax (952) 448-2613 • (800) 448-0121

Email: sales@acousticalsurfaces.com

Visit our Website: www.acousticalsurfaces.com

*We Identify and **S.T.O.P.** Your Noise Problem*

RSIC-DC04

RSIC-DC04 CLIP DIMENSIONS

