



# Acoustical Surfaces, Inc.

**SOUNDPROOFING, ACOUSTICS, NOISE & VIBRATION CONTROL SPECIALISTS**

123 Columbia Court North • Suite 201 • Chaska, MN 55318

(952) 448-5300 • Fax (952) 448-2613 • (800) 448-0121

Email: [sales@acousticalsurfaces.com](mailto:sales@acousticalsurfaces.com)

Visit our Website: [www.acousticalsurfaces.com](http://www.acousticalsurfaces.com)

---

---

***We Identify and S.T.O.P. Your Noise Problem***



## Acousti-Banners

- *High Performance*
- *Durable*

Acousti-Banners are ideal for areas that have a large open space. Available in 1"; or 2" thickness with sizes up to 4' by 25' long. Acousti-Banners are easily installed on ceilings, with grommets.

**MATERIAL:** 2.0 PCF Core.

**APPLICATIONS:** Large open spaces.

**THICKNESS:** 2" or 4".

**SIZES:** Range max size 4'x25' long.

**FINISHES:** PVC, Sailcloth or Guilford Fabric.

**NRC RATING:** 2" – .85-.90; 4" – 1.00-1.15

**EDGE DETAIL:** Sewn Edges.

**FLAMMABILITY:** ASTM E-84 & CPAI 84.

**INSTALLATION:** Grommets.

*Continued on next page...*

- 
- Soundproofing Products • Sonex™ Ceiling & Wall Panels • Sound Control Curtains • Equipment Enclosures • Acoustical Baffles & Banners • Solid Wood & Veneer Acoustical Ceiling & Wall Systems
  - Professional Audio Acoustics • Vibration & Damping Control • Fire Retardant Acoustics • Hearing Protection • Moisture & Impact Resistant Products • Floor Impact Noise Reduction
  - Sound Absorbers • Noise Barriers • Fabric Wrapped Wall Panels • Acoustical Foam (Egg Crate) • Acoustical Sealants & Adhesives • Outdoor Noise Control • Assistive Listening Devices
  - OSHA, FDA, ADA Compliance • On-Site Acoustical Analysis • Acoustical Design & Consulting • Large Inventory • Fast Shipment • No Project too Large or Small • Major Credit Cards Accepted



# Acoustical Surfaces, Inc.

SOUNDPROOFING, ACOUSTICS, NOISE & VIBRATION CONTROL SPECIALISTS

123 Columbia Court North • Suite 201 • Chaska, MN 55318

(952) 448-5300 • Fax (952) 448-2613 • (800) 448-0121

Email: [sales@acousticalsurfaces.com](mailto:sales@acousticalsurfaces.com)

Visit our Website: [www.acousticalsurfaces.com](http://www.acousticalsurfaces.com)

**We Identify and S.T.O.P. Your Noise Problem**

## Attach to Beams or Bar Joists w/Cable Ends

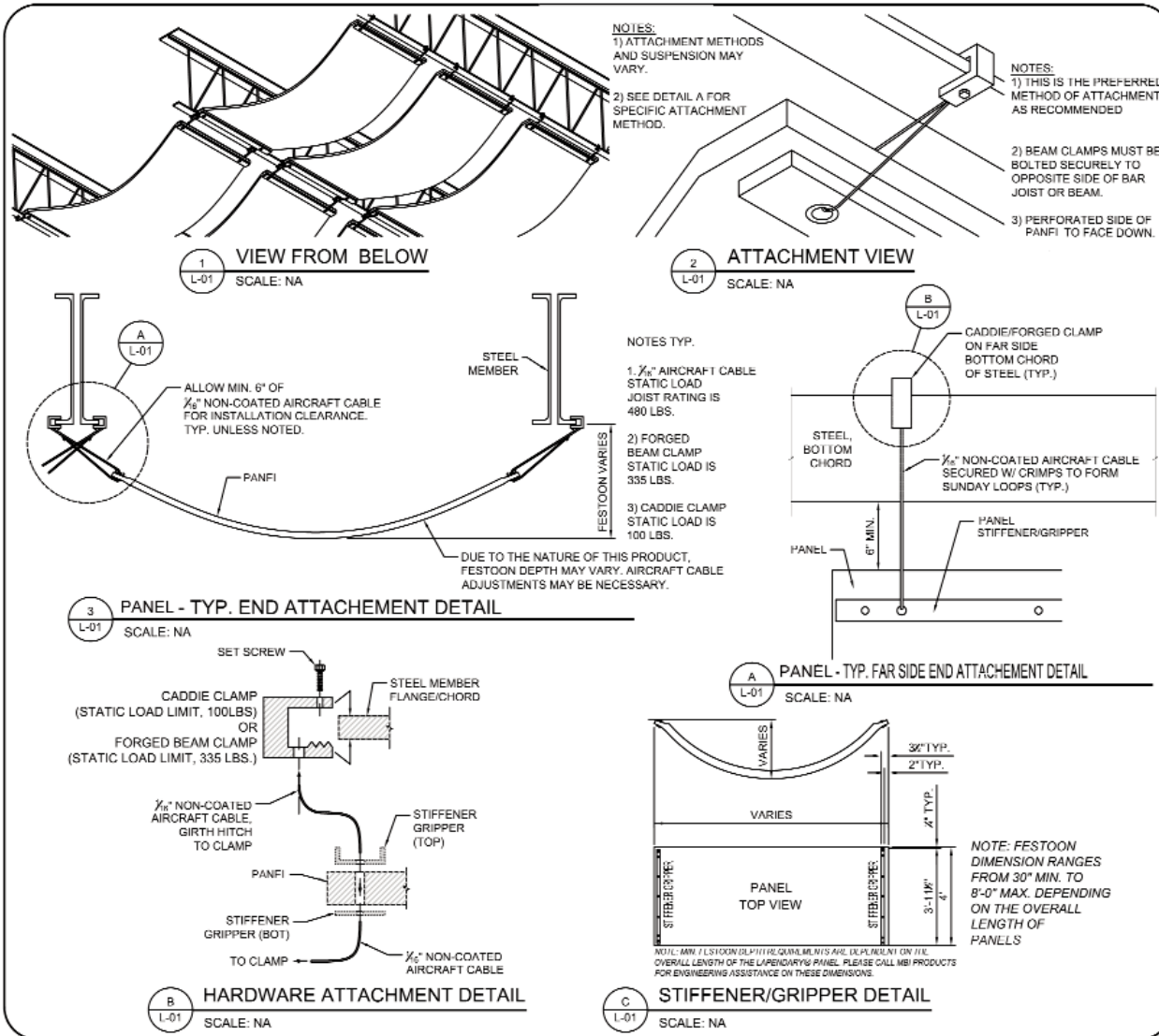

Revisions:	
No.	Description:

Sheet Description:  
**Attachment to Beams or Bar Joists with Cable Ends**

Drawn By: CFB  
Checked By: -  
Approved By: -

Date: 08/12/10  
Scale: VARIES

Drawing Ref: None  
Drawing: **L-01**

Continued on next page...

- Soundproofing Products • Sonex™ Ceiling & Wall Panels • Sound Control Curtains • Equipment Enclosures • Acoustical Baffles & Banners • Solid Wood & Veneer Acoustical Ceiling & Wall Systems
- Professional Audio Acoustics • Vibration & Damping Control • Fire Retardant Acoustics • Hearing Protection • Moisture & Impact Resistant Products • Floor Impact Noise Reduction
- Sound Absorbers • Noise Barriers • Fabric Wrapped Wall Panels • Acoustical Foam (Egg Crate) • Acoustical Sealants & Adhesives • Outdoor Noise Control • Assistive Listening Devices
- OSHA, FDA, ADA Compliance • On-Site Acoustical Analysis • Acoustical Design & Consulting • Large Inventory • Fast Shipment • No Project too Large or Small • Major Credit Cards Accepted



# Acoustical Surfaces, Inc.

**SOUNDPROOFING, ACOUSTICS, NOISE & VIBRATION CONTROL SPECIALISTS**

123 Columbia Court North • Suite 201 • Chaska, MN 55318

(952) 448-5300 • Fax (952) 448-2613 • (800) 448-0121

Email: [sales@acousticalsurfaces.com](mailto:sales@acousticalsurfaces.com)

Visit our Website: [www.acousticalsurfaces.com](http://www.acousticalsurfaces.com)

**We Identify and S.T.O.P. Your Noise Problem**

## Direct Attachment to Roof Deck

**NOTES:**

1) ON SINGLE BANNER RUNS, DIRECT ATTACHMENT MAY BE USED ON BOTH ENDS.

2) ON MULTIPLE BANNER RUNS, ADJUSTABLE ATTACHMENT TO BE USED ON BOTH ENDS. SEE DETAIL 2/L-02.

3) PERFORATED SIDE OF PANEL TO FACE DOWN.

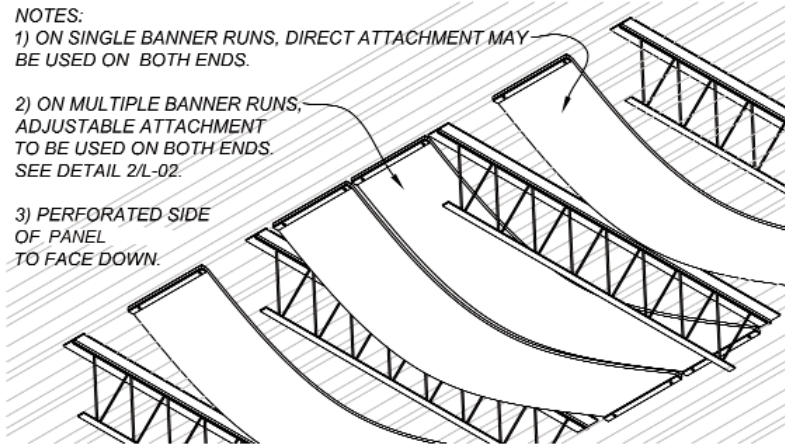

1  
L-02  
VIEW FROM BELOW  
SCALE: NA

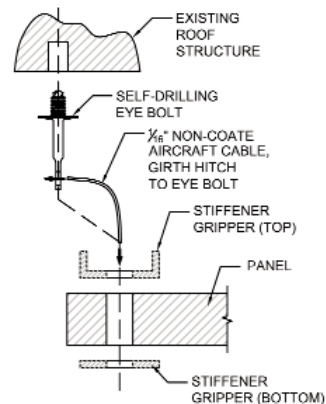

A  
L-02  
HARDWARE ATTACHMENT DETAIL  
SCALE: NA

NOTE: DETAIL DRAWN TO SHOW SUSPENSION ATTACHMENTS ONLY. IT IS NOT REPRESENTATIVE OF AN ACTUAL INSTALLATION.

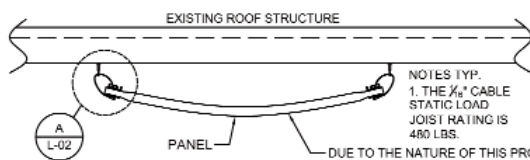

2  
L-02  
PANEL - TYP. END ATTACHEMENT DETAIL  
SCALE: NA

NOTES TYP.  
1. THE 1/8" CABLE STATIC LOAD JOIST RATING IS 480 LBS.  
DUE TO THE NATURE OF THIS PRODUCT, FESTOON DEPTH MAY VARY. AIRCRAFT CABLE ADJUSTMENTS MAY BE NECESSARY.

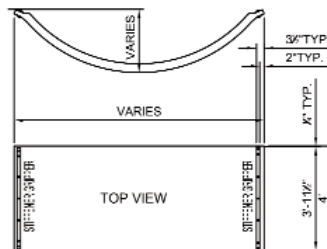

B  
L-02  
STIFFENER/GRIPPER DETAIL  
SCALE: NA

NOTE: MAX. FESTOON DEPTH REQUIREMENTS ARE DEPENDENT ON THE OVERALL LENGTH OF THE PANEL.

Revisions:		
No.	Date:	Description:

Sheet Description:  
**Direct Attachment to Roof Deck**

Drawn By:	CPB
Checked By:	-
Approved By:	-

Date:	08/13/10
Scale:	VARIES
Drawing Ref:	None
Drawing:	<b>L-02</b>

Continued on next page...

- Soundproofing Products • Sonex™ Ceiling & Wall Panels • Sound Control Curtains • Equipment Enclosures • Acoustical Baffles & Banners • Solid Wood & Veneer Acoustical Ceiling & Wall Systems
- Professional Audio Acoustics • Vibration & Damping Control • Fire Retardant Acoustics • Hearing Protection • Moisture & Impact Resistant Products • Floor Impact Noise Reduction
- Sound Absorbers • Noise Barriers • Fabric Wrapped Wall Panels • Acoustical Foam (Egg Crate) • Acoustical Sealants & Adhesives • Outdoor Noise Control • Assistive Listening Devices
- OSHA, FDA, ADA Compliance • On-Site Acoustical Analysis • Acoustical Design & Consulting • Large Inventory • Fast Shipment • No Project too Large or Small • Major Credit Cards Accepted



# Acoustical Surfaces, Inc.

SOUNDPROOFING, ACOUSTICS, NOISE & VIBRATION CONTROL SPECIALISTS

123 Columbia Court North • Suite 201 • Chaska, MN 55318

(952) 448-5300 • Fax (952) 448-2613 • (800) 448-0121

Email: [sales@acousticalsurfaces.com](mailto:sales@acousticalsurfaces.com)

Visit our Website: [www.acousticalsurfaces.com](http://www.acousticalsurfaces.com)

**We Identify and S.T.O.P. Your Noise Problem**

## Bar Joist Suspension w/Cable Support

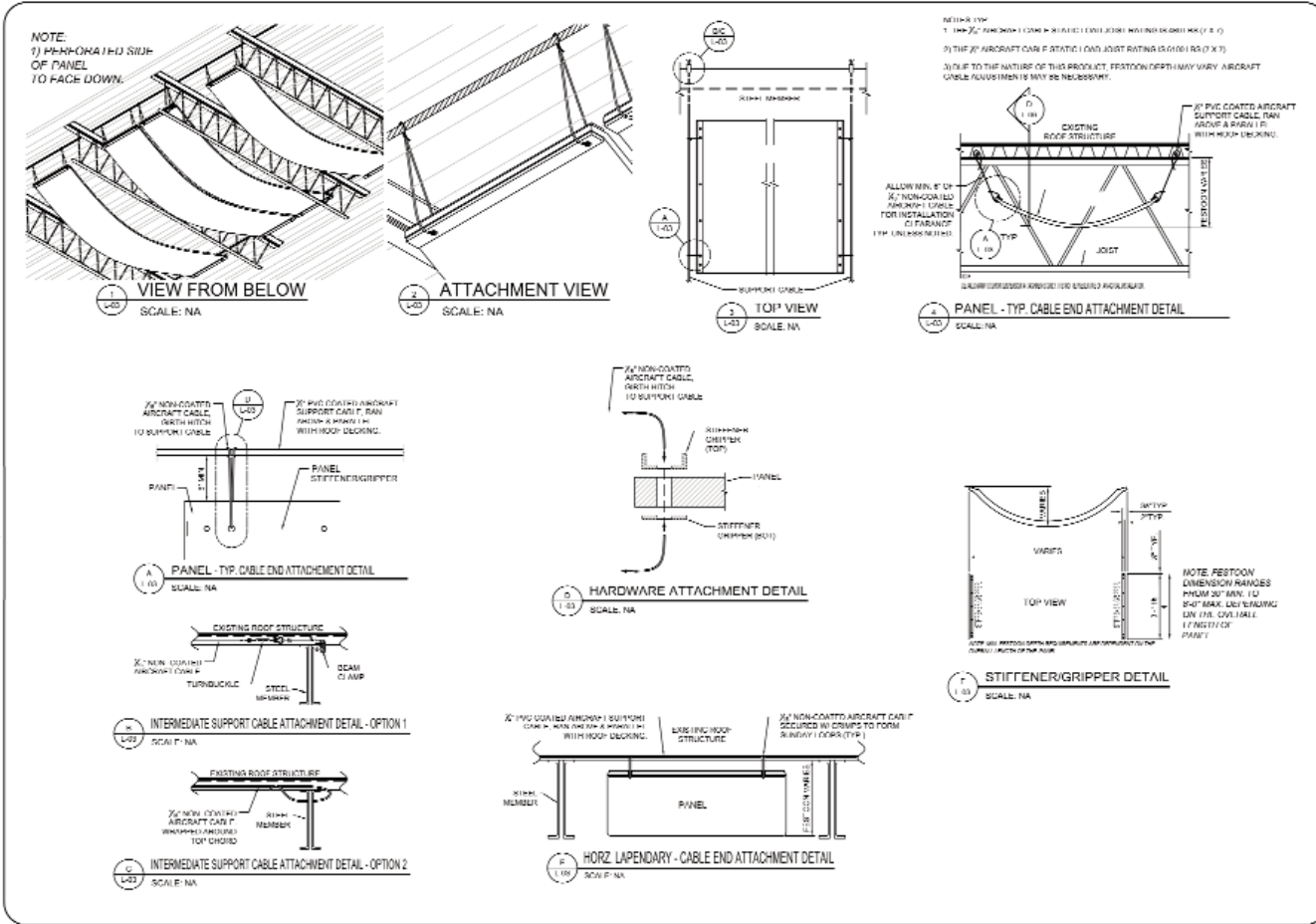

Revis.	Date	Description

Sheet Description:  
**Bar Joist Suspension w/ Cable Support**

Key Plan

Drawn By: JPM  
Checked By:  
Approved By:

MS/Passive Company, Inc.  
Date: 5/20/11  
Scale: 1/8" = 1'-0"  
Drawing/Rev: None

Drawing: **L-03**

- Soundproofing Products • Sonex™ Ceiling & Wall Panels • Sound Control Curtains • Equipment Enclosures • Acoustical Baffles & Banners • Solid Wood & Veneer Acoustical Ceiling & Wall Systems
- Professional Audio Acoustics • Vibration & Damping Control • Fire Retardant Acoustics • Hearing Protection • Moisture & Impact Resistant Products • Floor Impact Noise Reduction
- Sound Absorbers • Noise Barriers • Fabric Wrapped Wall Panels • Acoustical Foam (Egg Crate) • Acoustical Sealants & Adhesives • Outdoor Noise Control • Assistive Listening Devices
- OSHA, FDA, ADA Compliance • On-Site Acoustical Analysis • Acoustical Design & Consulting • Large Inventory • Fast Shipment • No Project too Large or Small • Major Credit Cards Accepted